

SYMMETRIC GROUP ON FOUR ELEMENTS

A first absolutely non-trivial example for all the stuff we went through is the symmetric group on four elements, \mathfrak{S}_4 . It acts in a natural way on the four corners of a tetrahedron by permutation. You can create these permutations by reflections, rotations and combinations of both. However, we would like to look at the action of \mathfrak{S}_4 on a cube.

Conjugacy classes. The conjugacy classes of symmetric groups can be obtained very easily: The group \mathfrak{S}_n has precisely $n!$ elements, which fall into $p(n)$ conjugacy classes. Here, $p(n)$ denotes the number of partitions of the natural number n in sums of natural numbers. For example, $p(4) = 5$, since 4 can be written as

$$\{4, 3 + 1, 2 + 1 + 1, 1 + 1 + 1 + 1, 2 + 2\}.$$

Therefore \mathfrak{S}_4 should have five conjugacy classes. Typically, you just give a representative of the class. To obtain one, note that you can define for a partition $n = n_1 + \dots + n_k$ the group element

$$n_1 + \dots + n_k \mapsto (1 \dots n_1)(n_1 + 1 \dots n_1 + n_2) \dots (n_1 + \dots + n_{k-1} + 1 \dots n_1 + \dots + n_{k-1} + n_k)$$

made out of k disjoint cycles. Cycle of one element only are trivial, and are therefore often omitted in the notation. A cycle $(i_1 i_2 \dots i_m)$ describes the permutation $\begin{pmatrix} i_1 & i_2 & i_3 & \dots & i_{m-1} & i_m \\ i_m & i_1 & i_2 & \dots & i_{m-2} & i_{m-1} \end{pmatrix}$. In our example \mathfrak{S}_4 , we find representatives of the five conjugacy classes as follows:

Partition	representative g	$c(g)$	$[g]$
1+1+1+1	1 = (1)(2)(3)(4)	1	e
2+1+1	(12) = (12)(3)(4)	6	C_2
3+1	(123) = (123)(4)	8	C_3
4	(1234)	6	C_4
2+2	(12)(34)	3	C_2^2

It is important to understand that each representative of a class is mapped under conjugation with any group element into an element which has an equivalent decomposition into cycles. Consider for example the representative $g = (123)$ for the conjugacy class of the 3-cycles. Under conjugation $h^{-1}gh$, this goes to $\begin{pmatrix} i_1 & i_2 & i_3 & i_4 \\ i_1 & i_2 & i_3 & i_4 \end{pmatrix} (123) \begin{pmatrix} 1 & 2 & 3 & 4 \\ i_1 & i_2 & i_3 & i_4 \end{pmatrix} = \begin{pmatrix} i_1 & i_2 & i_3 & i_4 \\ 2 & 3 & 1 & 4 \end{pmatrix} \begin{pmatrix} 1 & 2 & 3 & 4 \\ i_1 & i_2 & i_3 & i_4 \end{pmatrix} = \begin{pmatrix} i_3 & i_1 & i_2 & i_4 \\ 1 & 2 & 3 & 4 \end{pmatrix} \begin{pmatrix} 1 & 2 & 3 & 4 \\ i_1 & i_2 & i_3 & i_4 \end{pmatrix} = \begin{pmatrix} i_3 & i_1 & i_2 & i_4 \\ i_1 & i_2 & i_3 & i_4 \end{pmatrix} = (i_1 i_2 i_3)$, which indeed is again a 3-cycle. In the same manner, we can understand how many elements a given class possesses. An m -cycle g has per definition order m , i.e. $g^m = 1$. Therefore, there are $(m-1)! \binom{n}{m}$ distinct m -cycles on n elements. It gets a bit more complicated to compute this for classes which consist out of several non-trivial cycles. The result for a conjugacy class, which is built out of p_1 1-cycles, p_2 2-cycles etc., which hence belongs to the partition

$$n = \underbrace{1 + \dots + 1}_{p_1} + \underbrace{2 + \dots + 2}_{p_2} + \dots + \underbrace{n}_{p_n} \mapsto g = C_1^{p_1} C_2^{p_2} \dots C_n^{p_n},$$

is given by

$$c(g) = n! \left(\prod_{m=1}^n m^{p_m} p_m! \right)^{-1}.$$

In this way you find the number $c(g)$ of elements of a conjugacy class $[g]$ for our example \mathfrak{S}_4 , as given in the above table.

Character table. With the conjugacy classes as found above, we can now compute the characters of the irreps. The character table for \mathfrak{S}_4 reads

\mathfrak{S}_4	e	$6C_2$	$8C_3$	$6S_4$	$3C_{2,2}$
U	1	1	1	1	1
U'	1	-1	1	-1	1
V	3	1	0	-1	-1
V'	3	-1	0	1	-1
W	2	0	-1	0	2

The first three irreps are easily identified, they are the trivial, the alternating and the standard irrep, respectively, $U = Trv$, $U' = Alt$, and $V = Std$. Note that the standard irrep of \mathfrak{S}_n is given by the quotient of the permutation

representation on n elements with the diagonal invariant subspace (equivalent to the trivial representation). Thus, it has dimension $n - 1$. Now, the character of the permutation representations is very easy to compute, it is simply the number of elements fixed by the action of the group element considered, because these are the only non-zero diagonal matrix elements. Thus $\chi_{Std} = \chi_{Permut} - \chi_{Triv}$. One might guess that the representation $V' = V \otimes U'$ is irreducible, with character $\chi_{V'}(g) = \chi_V(g)\chi_{U'}(g)$, and indeed $(\chi_{V'}, \chi_{V'}) = 1$. Moreover, $\chi_{V'}$ is linearly independent from the other three characters. So, since there can only be five irreps, we must find one irrep W of dimension two, since $24 = 1^2 + 1^2 + 3^2 + 3^2 + x^2$, such that $x = 2$. Now, since the regular representation of any finite group G is complete, we can determine the fifth character by simply using

$$\begin{aligned} \sum_{\chi} \overline{\chi(g)}\chi(g) &= \frac{|G|}{c(g)}, \\ \sum_{\chi} \overline{\chi(g)}\chi(h) &= 0 \quad \text{für } h \notin [g]. \end{aligned}$$

In these formulæ, the sum runs over the characters of all irreps. To determine the dimension of the sought fifth irrep, one has to solve the equation $\sum_{\chi} \overline{\chi(e)}\chi(e) = 24$. In an analogous way, you obtain the values of χ_W for all the other conjugacy classes.

Remark. The irrep W has for C_2^2 the character value $\chi(C_2^2) = 2$. Now, C_2^2 is an involution, which has on W trace two. Since W has dimension two, it follows that C_2^2 acts as identity on W . We can make a general remark here: Let $N \subset G$ a normal subgroup, i.e. $gN \in N$ and $Ng \in N$ for all $g \in G$. Let a representation $\rho : G \rightarrow GL(W)$ be trivial on N . Then we have a faktorization $G \rightarrow G/N \rightarrow GL(W)$, i.e. we can identify representations of G/N with representations of G , which are trivial on N . In our example $N = \langle e, (12)(34), (13)(24), (14)(23) \rangle$, and W is a representation of the quotient group $\mathfrak{S}_4/N \simeq \mathfrak{S}_3$. More precisely, one can see that W is the standard representation of \mathfrak{S}_3 . One also says that W is the pull back of \mathfrak{S}_3 to \mathfrak{S}_4 .

Interpretation. The symmetric group \mathfrak{S}_4 can be viewed as the group of movements of a cube, which map it onto itself. This includes movements one can perform in real space, such as rotations and translations, but not reflections! The group acts on the four main diagonals of the cube. Then, \mathfrak{S}_3 is the quotient group which operates on the three pairs of opposed faces. To explain this a bit better, here some pictures:

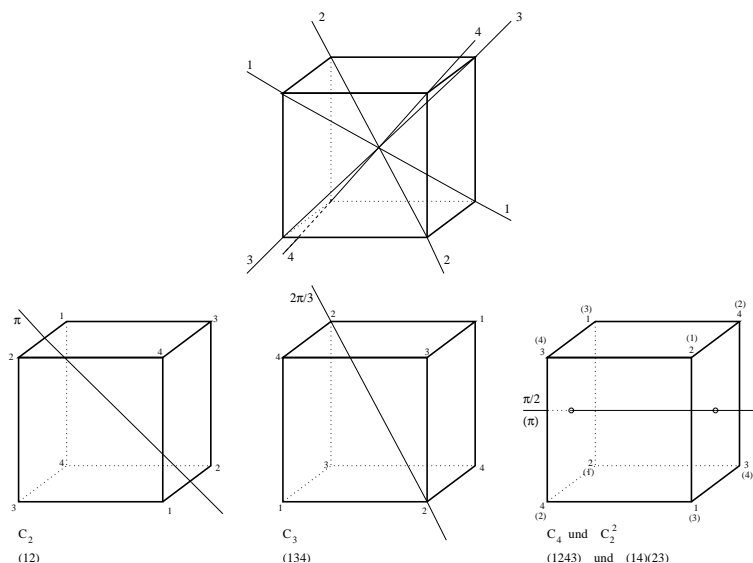

Please note that the corresponding rotations around the main diagonals act correctly as they should, but they automatically induce a representation of the group acting on the faces. Of course, they also induce a representation on the edges or the corners, respectively. These are permutation representations of dimensions 6, 12 and 8, respectively. The best thing is to take a dice and check it out for yourself. On an admissible dice, the opposing faces show the number pairs (1,6), (2,5) and (3,4). You can check yourself where these faces are mapped to under rotations around the main diagonals. Since these are permutation representations, the character values are simply the numbers of faces left invariant under such a rotation. It follows that $\chi(C_2) = \chi(C_3) = 0$ and $\chi(C_4) = \chi(C_2^2) = 2$. Thus, we find the character for the representation on the faces as $\chi_{\text{faces}} = (6, 0, 0, 2, 2)$. Furthermore, $(\chi, \chi) = \frac{1}{24}(1 \cdot 6^2 + 6 \cdot 0 + 8 \cdot 0 + 6 \cdot 2^2 + 3 \cdot 2^2) = 3$, such that the representation on the faces is a sum of three irreps. With the help of the character table, one easily finds out that $(\chi, \chi_U) = (\chi, \chi_{V'}) = (\chi, \chi_W) = 1$, and that all other scalar products of χ with another irreducible character vanish. Thus, the face representation is isomorphic to $U \oplus V' \oplus W$. Therefore, this six-dimensional representation has a three-dimensional subrepresentation, which is spanned by the sums of the three opposing pairs of faces. Since it obviously contains the sum of all faces, it

contains the trivial irrep. Thus, it must be $U \oplus W$. The differences of the opposing pairs of faces must hence span the remaining 3-dimensional irrep, which is V' .

Representation in detail. Assign to each face i a base vector $|i\rangle$ of a ortho-normal base of \mathbb{R}^6 , since the face representation is 6-dimensional. As on any regular dice, the opposing pairs of faces show the numbers (1, 6), (2, 5) and (3, 4). In order to make it possible to compare configurations, our starting position in the following will be a dice where the one is on the front, the two on the left side, and the three on top. This looks as follows:

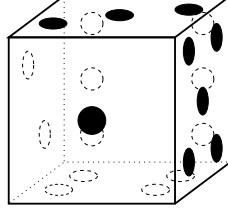

The representatives of the conjugacy classes shown in the pictures are then given by the following explicit 6×6 matrices:

$$\rho_{\text{Flächen}}((12)) = \begin{pmatrix} 0 & 0 & 0 & 0 & 0 & 1 \\ 0 & 0 & 1 & 0 & 0 & 0 \\ 0 & 1 & 0 & 0 & 0 & 0 \\ 0 & 0 & 0 & 0 & 1 & 0 \\ 0 & 0 & 0 & 1 & 0 & 0 \\ 1 & 0 & 0 & 0 & 0 & 0 \end{pmatrix}, \quad \rho_{\text{Flächen}}((134)) = \begin{pmatrix} 0 & 0 & 0 & 0 & 1 & 0 \\ 0 & 0 & 1 & 0 & 0 & 0 \\ 0 & 0 & 0 & 0 & 0 & 1 \\ 1 & 0 & 0 & 0 & 0 & 0 \\ 0 & 0 & 0 & 1 & 0 & 0 \\ 0 & 1 & 0 & 0 & 0 & 0 \end{pmatrix},$$

$$\rho_{\text{Flächen}}((1243)) = \begin{pmatrix} 0 & 0 & 1 & 0 & 0 & 0 \\ 0 & 1 & 0 & 0 & 0 & 0 \\ 0 & 0 & 0 & 0 & 0 & 1 \\ 1 & 0 & 0 & 0 & 0 & 0 \\ 0 & 0 & 0 & 0 & 1 & 0 \\ 0 & 0 & 0 & 1 & 0 & 0 \end{pmatrix}, \quad \rho_{\text{Flächen}}((14)(23)) = \begin{pmatrix} 0 & 0 & 0 & 0 & 0 & 1 \\ 0 & 1 & 0 & 0 & 0 & 0 \\ 0 & 0 & 0 & 1 & 0 & 0 \\ 0 & 0 & 1 & 0 & 0 & 0 \\ 0 & 0 & 0 & 0 & 1 & 0 \\ 1 & 0 & 0 & 0 & 0 & 0 \end{pmatrix}.$$

Choose now a new base in this 6-dimensional vector space by using the sums and differences of the base vectors corresponding to the opposing face pairs, i.e. put $|s_{16}\rangle = |1\rangle + |6\rangle$, $|s_{25}\rangle = |2\rangle + |5\rangle$, $|s_{34}\rangle = |3\rangle + |4\rangle$, $|d_{16}\rangle = |1\rangle - |6\rangle$, $|d_{25}\rangle = |2\rangle - |5\rangle$, $|d_{34}\rangle = |3\rangle - |4\rangle$. One checks easily that all the $|d_{ij}\rangle$ are orthogonal to the $|s_{i'j'}\rangle$. We can now explicitly perform the reduction of the reducible 6-dimensional face representation into irreps. U is a 1-dimensional vector space and is spanned by $|u\rangle = |s_{16}\rangle + |s_{25}\rangle + |s_{34}\rangle = |1\rangle + |2\rangle + |3\rangle + |4\rangle + |5\rangle + |6\rangle$. The 3-dimensional subspace, which is spanned by the vectors $|s_{ij}\rangle$, decomposes therefore into the direct sum $U \oplus W$, where the 2-dimensional space W is spanned, for instance, by the two vectors $|w_1\rangle = |s_{16}\rangle + |s_{25}\rangle - 2|s_{34}\rangle = |1\rangle + |2\rangle - 2|3\rangle - 2|4\rangle + |5\rangle + |6\rangle$ and $|w_2\rangle = |s_{16}\rangle - |s_{25}\rangle = |1\rangle - |2\rangle - |5\rangle + |6\rangle$. Indeed, $|w_1\rangle, |w_2\rangle$ are both orthogonal to $|u\rangle$, and also mutually orthogonal. The representation on U is, of course, trivial, i.e. $\rho_U(g) = 1$ for all $g \in \mathfrak{S}_4$. It is interesting to compute the representation on W explicitly. Using again the same representatives of the conjugacy classes, we find in the base $|w_1\rangle, |w_2\rangle$ the matrices

$$\rho_W((12)) = \begin{pmatrix} -1/2 & 3/2 \\ 1/2 & 1/2 \end{pmatrix}, \quad \rho_W((134)) = \begin{pmatrix} -1/2 & 3/2 \\ -1/2 & -1/2 \end{pmatrix},$$

$$\rho_W((1243)) = \begin{pmatrix} -1/2 & -3/2 \\ -1/2 & 1/2 \end{pmatrix}, \quad \rho_W((14)(23)) = \begin{pmatrix} 1 & 0 \\ 0 & 1 \end{pmatrix}.$$

This confirms that C_2^2 acts indeed trivially on W . The traces of these matrices yield precisely the values which would expect from the character table, as it should be. If you wish, you can now go on and compute the matrices for $\rho_{V'}(g)$.

Exercise. Redo the above analysis for the edges and corners of the cube. You can check your results with these data:

Representation	Decomposition	Dimensions
face representation	$= U \oplus V' \oplus W$	$1 + 3 + 2 = 6$
corner representation	$= U \oplus V \oplus U' \oplus V'$	$1 + 3 + 1 + 3 = 8$
edge representation	$= U \oplus 2V \oplus V' \oplus W$	$1 + 2 \cdot 3 + 3 + 2 = 12$.

Alternating group. For completeness, we briefly consider the alternating subgroup $\mathfrak{A}_4 \subset \mathfrak{S}_4$, which is generated as $\mathfrak{A}_4 = \langle e, (123), (12)(34) \rangle$. Note first that $\mathfrak{A}_4 / \langle e, (12)(34), (13)(24), (14)(23) \rangle \simeq \mathbb{Z}_3$. With $\omega = e^{2\pi i/3}$ a third root of unity, we easily find the character table:

\mathfrak{A}_4	e	$4(123)$	$4(132)$	$3(12)(34)$
U	1	1	1	1
U'	1	ω	ω^2	1
U''	1	ω^2	ω	1
V	3	0	0	-1

The first three rows are clear, since \mathfrak{A}_4 again contains the normal subgroup mentioned above. The last row is then again obtained from the completeness relations for the characters. The relations between the irreps of \mathfrak{S}_4 and \mathfrak{A}_4 are given by the following restrictions to the subgroup:

representation of \mathfrak{S}_4	restriction	representation of \mathfrak{A}_4
U	}	U ,
U'		
V	}	V ,
V'		
W	\longrightarrow	$U' \oplus U''$.

According to this, the representations U, U', V and V' of \mathfrak{S}_4 remain irreducible under restriction to \mathfrak{A}_4 , while the representation W decomposes under restriction to the subgroup \mathfrak{A}_4 in two irreducible subrepresentations, $U' \oplus U''$. Note for this that $\omega + \omega^2 = -1$. Furthermore, the pairs U, U' and V, V' become isomorphic, respectively, under the restriction.

Octahedron and cube — duality. The cube has 6 faces, 12 edges and 8 corners. The octahedron has 8 faces, 12 edges and 6 corners. There is a formal duality between the cube and the octahedron which is obtained by replacing the center points of the faces by corners and vice versa. A consequence of this is that the groups of rigid movements of cube and octahedron are identical. We can use this to work out the symmetry constraints of an f -electron in an octahedral crystal. To clarify this a bit, we show the corresponding rotations as acting on the octahedron:

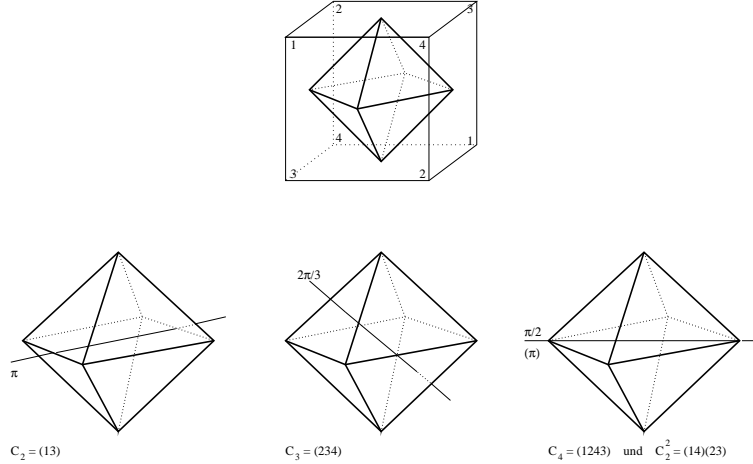

The natural permutation representation on the cube, namely the one acting on the four main diagonals, transforms into the natural permutation representation on the octahedron acting on the four pairs of opposing faces, which are penetrated by the four main diagonals of the cube in which the octahedron is embedded. Note that again the number $c(g)$ of elements per conjugacy class is correct.

The electron. We need to know the character of an arbitrary rotation $R = \exp(i\varphi \cdot L)$. Now, we know that such a rotation acts as $R : Y_{\ell m} = e^{im\varphi} P_{\ell}(\cos \theta) \mapsto e^{im\varphi} Y_{\ell m}$ where $\varphi = \varphi \hat{r}$. This follows from the explicit representation of the generators in the base L_3 and L^{\pm} . Thus, $\chi_{\ell}(\varphi) = \text{tr}_{\ell}(e^{i\varphi L_3}) = \sum_{m=-\ell}^{\ell} e^{im\varphi} = \sum_{m=-\ell}^{\ell} \cos(m\varphi) = \frac{\sin((2\ell+1)\varphi/2)}{\sin(\varphi/2)}$. Thus, we find for the particular angles φ associated with the allowed discrete rotations in the octahedron, i.e. 0 for e , π for 6C_2 , $\frac{2}{3}\pi$ for 8C_3 , $\pi/2$ for 6C_4 and again π for ${}^3C_{2,2}$, that $\chi_{\ell=3}(\varphi) = (7, -1, 1, -1, -1)$, where $\ell = 3$ is the angular momentum of an f -electron. This can be reduced into irreps since $\chi_{\ell=3} = \chi_{U'} + \chi_V + \chi_{V'}$. Thus the sevenfold degeneracy splits into three lines, two of them still threefold degenerate, and one is not degenerate.

Selection rules. Determine now which of the matrix elements of the position operator r can be non-zero. It is sufficient to determine this for states transforming in irreps, i.e. $\langle \Psi^{(\beta)} | r | \Psi^{(\alpha)} \rangle$ where α, β denote irreps.